

WMM 6...type Manual Operated Directional Control Valve



WMM6...6XJ... type

Size 6
Max. Working Pressure: 315 bar
Max. Flow: 60L/min

Contents

Function and configuration	02
Specification	03
Symbols	03
Technical data	04
Characteristic curves	04
Operating limitation	05
Unit dimensions	06

Features

- Direct operating directional spool valves
- For sub-plates mounting
- Hand lever
- Porting pattern confirms to DIN 24 340 form A, and ISO 4401

Function and configurations

WMM6...6XJ... type manual directional Valves are direct operated spool valves which switch the flow fluid by rotating the handle to move the spool axially. The valves consist of valve housing(1), handle(2), control spool(3), and one or two return springs(4).

The return springs (4) maintain the control spool (3) in central position when the handle is not operate. If the rotary button is actuated with a detent, the control spool (3) is moved to the desired spool position by the type of actuation (2).

Detent

02

Directional valves with rotary button are generally designed with detent. Directional valves with hand lever are optionally available as 2 or 3 position valves with detent. Directional valves with roller plunger are generally designed without detent. If types of actuation with detent are used, each spool position can be locked, depending on the valve type.

Throttle

The use of a throttle insert is required when due to given operating conditions, flows can occur during the switching processes that exceed the performance limit of the valve. These throttles are to be inserted into the P-channel of the directional valve.

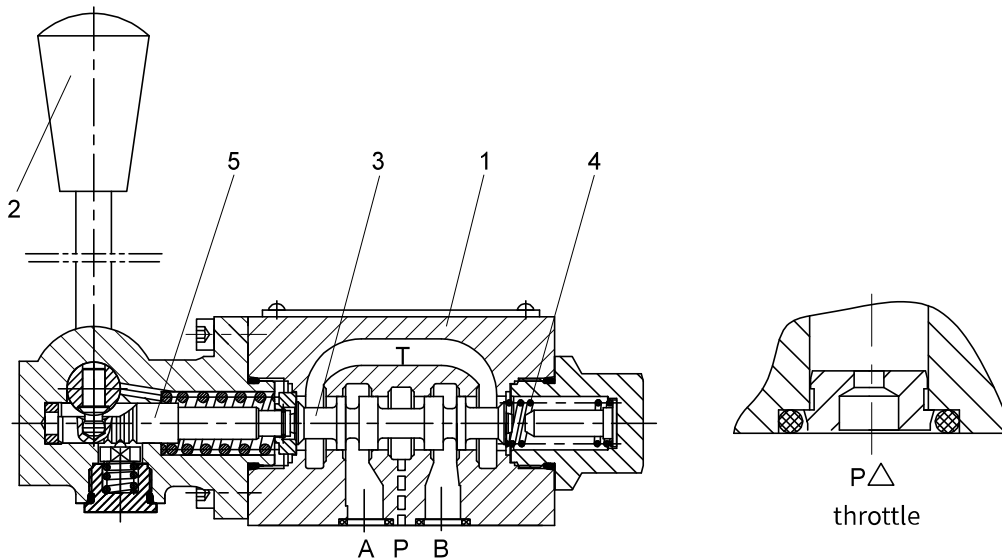

Specification

	WMM	6	- 6XJ /			*
3 ways (version A and B) =3			Further details in clear text			
4 ways =4			No code = NBR seals V = FKM seals			
Manual directional valve			No code = Without cartridge throttle B08 = Throttle - Φ0.8 mm B10 = Throttle - Φ1.0 mm B12 = Throttle - Φ1.2 mm			
Nominal size 6 =6			No code = Return spring F = With detent			
Symbols e.g. C, E, EA, EB etc. see below)						
Series 60J to 69J =6XJ (60J to 69J: unchanged installation and connection dimensions)						

Symbols

<p>Transition position</p> <p>AB</p> <p>PT</p> <p>=A</p> <p>=C</p> <p>=D</p>	<p>Spool valve symbols</p> <p>AB</p> <p>PT</p> <p>=A</p> <p>=C</p> <p>=D</p>	<p>Transition position</p> <p>AB</p> <p>PT</p> <p>=B</p> <p>=Y</p>	<p>Spool valve symbols</p> <p>AB</p> <p>PT</p> <p>=B</p> <p>=Y</p>	<p>Transition position</p> <p>AB</p> <p>PT</p> <p>=E</p> <p>=F</p> <p>=G</p> <p>=H</p> <p>=J</p> <p>=L</p> <p>=M</p> <p>=P</p> <p>=Q</p> <p>=R</p> <p>=T</p> <p>=U</p> <p>=V</p> <p>=W</p>	<p>Spool valve symbols</p> <p>AB</p> <p>PT</p> <p>=E</p> <p>=F</p> <p>=G</p> <p>=H</p> <p>=J</p> <p>=L</p> <p>=M</p> <p>=P</p> <p>=Q</p> <p>=R</p> <p>=T</p> <p>=U</p> <p>=V</p> <p>=W</p>	<p>Transition position</p> <p>AB</p> <p>PT</p> <p>=EA</p> <p>=FA</p> <p>=GA</p> <p>=HA</p> <p>=JA</p> <p>=LA</p> <p>=MA</p> <p>=PA</p> <p>=QA</p> <p>=RA</p> <p>=TA</p> <p>=UA</p> <p>=VA</p> <p>=WA</p>	<p>Spool valve symbols</p> <p>AB</p> <p>PT</p> <p>=EA</p> <p>=FA</p> <p>=GA</p> <p>=HA</p> <p>=JA</p> <p>=LA</p> <p>=MA</p> <p>=PA</p> <p>=QA</p> <p>=RA</p> <p>=TA</p> <p>=UA</p> <p>=VA</p> <p>=WA</p>	<p>Transition position</p> <p>AB</p> <p>PT</p> <p>=EB</p> <p>=FB</p> <p>=GB</p> <p>=HB</p> <p>=JB</p> <p>=LB</p> <p>=MB</p> <p>=PB</p> <p>=QB</p> <p>=RB</p> <p>=TB</p> <p>=UB</p> <p>=VB</p> <p>=WB</p>	<p>Spool valve symbols</p> <p>AB</p> <p>PT</p> <p>=EB</p> <p>=FB</p> <p>=GB</p> <p>=HB</p> <p>=JB</p> <p>=LB</p> <p>=MB</p> <p>=PB</p> <p>=QB</p> <p>=RB</p> <p>=TB</p> <p>=UB</p> <p>=VB</p> <p>=WB</p>
------------------------------------------------------------------------------	------------------------------------------------------------------------------	--------------------------------------------------------------------	--------------------------------------------------------------------	--------------------------------------------------------------------------------------------------------------------------------------------------------------------------------------------	--------------------------------------------------------------------------------------------------------------------------------------------------------------------------------------------	----------------------------------------------------------------------------------------------------------------------------------------------------------------------------------------------------------	----------------------------------------------------------------------------------------------------------------------------------------------------------------------------------------------------------	----------------------------------------------------------------------------------------------------------------------------------------------------------------------------------------------------------	----------------------------------------------------------------------------------------------------------------------------------------------------------------------------------------------------------

Technical data

Fixing position		Optional	
Fluid temperature range		°C	
		-30 to +80 (NBR seal)	
		-20 to +80 (FKM seal)	
Max. operating pressure	Port A,B,P	bar	315
	Port T	bar	160
Max. flow-rate		L/min	60
Flow cross section (switching neutral position)	Type Q	mm ²	For symbol Q 6% of nominal cross section
	Type W	mm ²	For symbol W 3% of nominal cross section
Fluid		Mineral oil for NBR and FKM seal	
		Phosphate ester for FKM seal	
Viscosity range		mm ² /s	2.8 to 500
Degree of contamination		Maximum permissible degree of fluid contamination: Class 9. NAS 1638 or 20/18/15, ISO4406	
Weight		kg	1.6

02

Characteristic curves (Measured at $t=40^{\circ}\text{C} \pm 5^{\circ}\text{C}$, using HLP46)

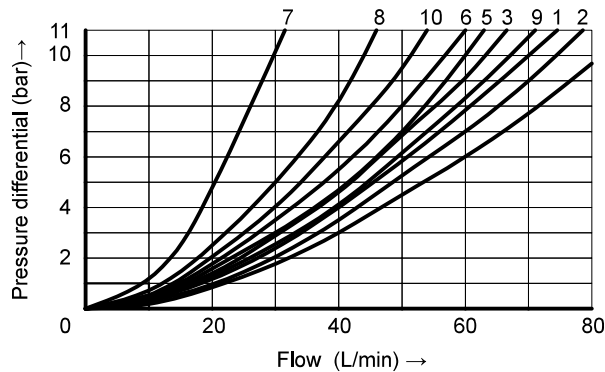

- 7 Symbol "R" in switched positions B → A
- 8 Symbol "G" and "T" in neutral position P → T
- 9 Symbol "H" in neutral position P → T

Spool symbol	Flow direction			
	P to A	P to B	A to T	B to T
A B	3	3	-	-
C	1	1	3	1
D Y	5	5	3	3
E	3	3	1	1
F	1	3	1	1
T	10	10	9	9
H	2	4	2	2
J Q	1	1	2	1
L	3	3	4	9
M	2	4	3	3
P	3	1	1	1
R	5	5	4	-
V	1	2	1	1
W	1	1	2	2
U	3	3	9	4
G	6	6	9	9

Operating limitations

The switching function of the valves depends on the filtration. To achieve the specified admissible flow values, we recommend full flow filtration with 25 µm. The flow forces acting within the valves also affect the flow performance. With 4 way valves the specified flow data thus apply to normal operation with 2 volume flow directions . If only one flow direction is available, in certain cases, the admissible flow can be significantly smaller.

Without detent

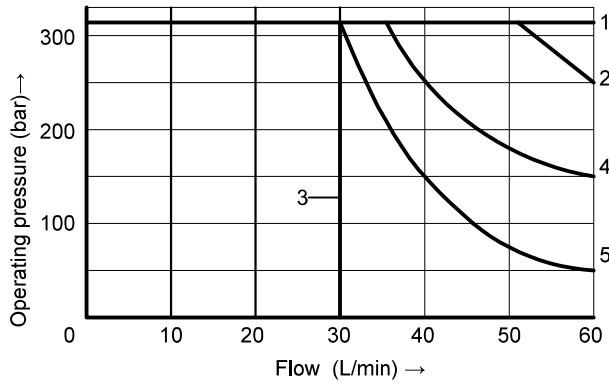

Curve	Spool symbol	
Without detent	1	M E,J L,Q,U,W C,D,Y,G H,R
	2	A,B
	3	V
	4	F,P
	5	T

With detent

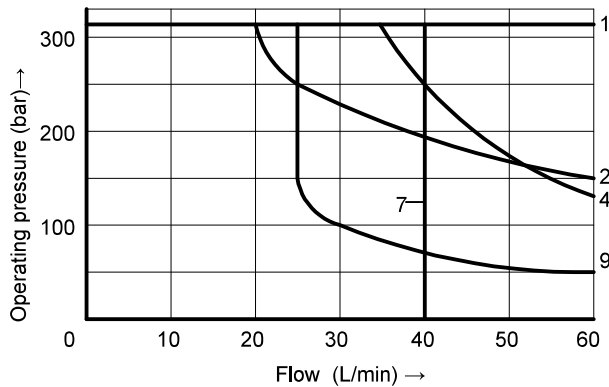

Curve	Spool symbol	
With detent	1	M H,C D,Y
	2	E,J,Q,L U,W
	3	A,B
	4	G,T
	5	F
	6	V
	7	P
	8	R
	9	T

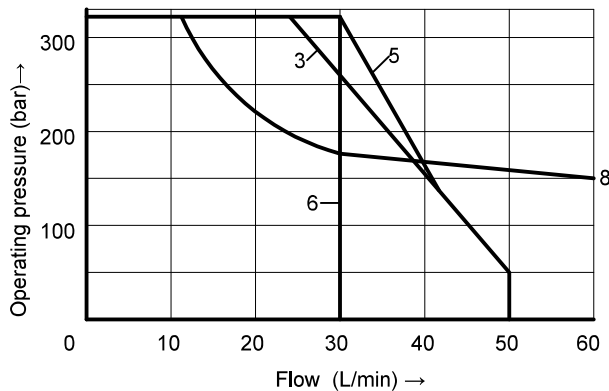

Unit dimensions

(Dimensions in mm)

02

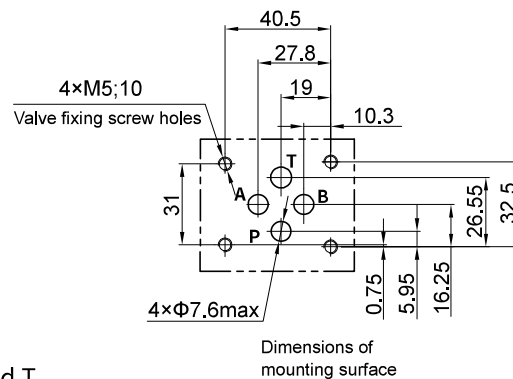
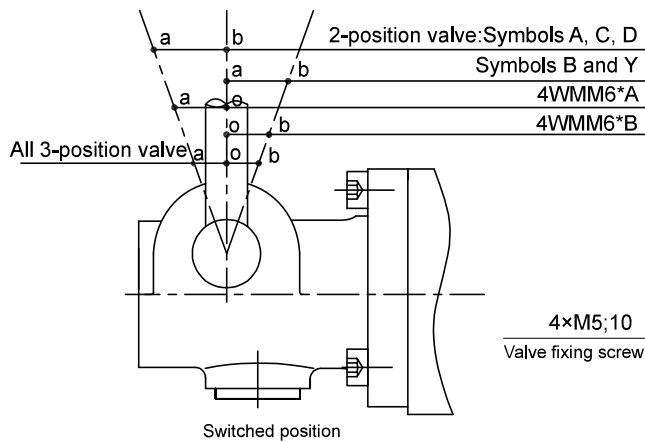
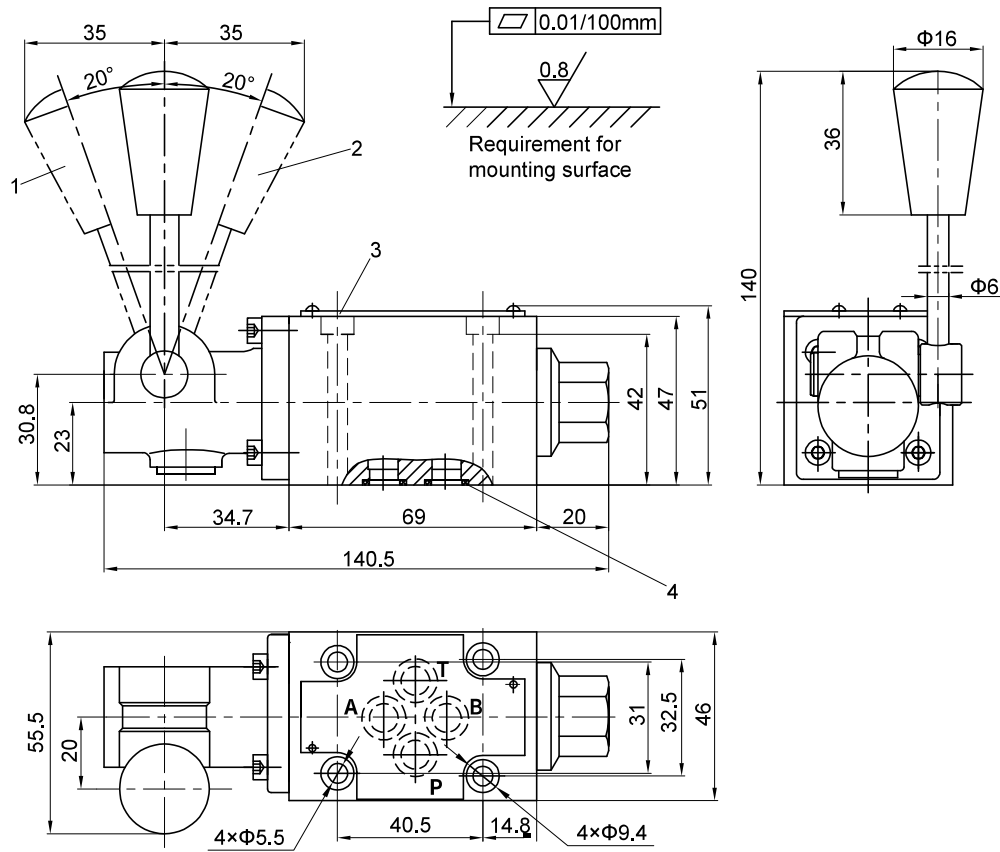

- 1 Switched position b → a, o → a
- 2 Switched position a → b, o → b
- 3 Nameplate
- 4 O-ring 9.25×1.78 for ports A, B, P and T