

WE6...Type Solenoid-Operated Directional Valve

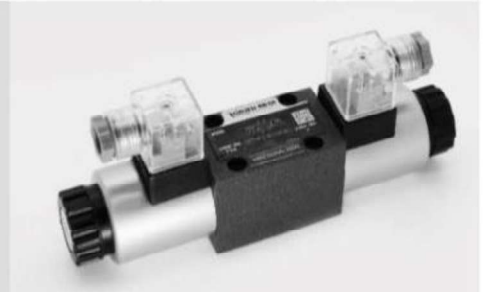

WE6...6XJ...type

Size (NG) 6

Max. Working Pressure: 315 bar

Max. Flow: 80 L/min

Contents

Function and configurations	02
Specifications	03
Symbols	04
Characteristic curves	04
Technical data	05
Electric data	05
Performance limits	06-07
Unit dimensions	08-09

Features

- Direct operated directional solenoid valve,
- Porting pattern according to DIN 24 340 form A, ISO 4401 and CETOP-RP 121 H
- Wet-pin AC or DC solenoids with detachable coil
- Pressure-tight chamber needs not to be opened for a coil change
- Electrical connection as individual or central connection

Function and configurations

WE6...6XJ...type valves are solenoid operated directional spool valves. They control the start, stop and direction of hydraulic oil flow. The directional control valves consist of valve Body (1), one or two solenoids (2), the valve core (3), and one or two return springs (4). In the de-energized condition the valve core (3) is held in the neutral or initial position by means of return springs (4) (except for impulse spools). The control spool (3) is actuated via wet pin Solenoids (2).

To ensure proper operation, the pressure chamber of the solenoid must be filled with oil. The valve core (3) is moved to the expected position by Solenoids (2) and pushing rod (5). This gives Mfree-flow from P to A and B to T or P to B and A to T. When solenoid (2) is de-energized, the valve core (3) is Returned to its initial position by means of the return springs (4). The solenoids may also control the valve core (3) by an optional override button (6) under the de-energized condition.

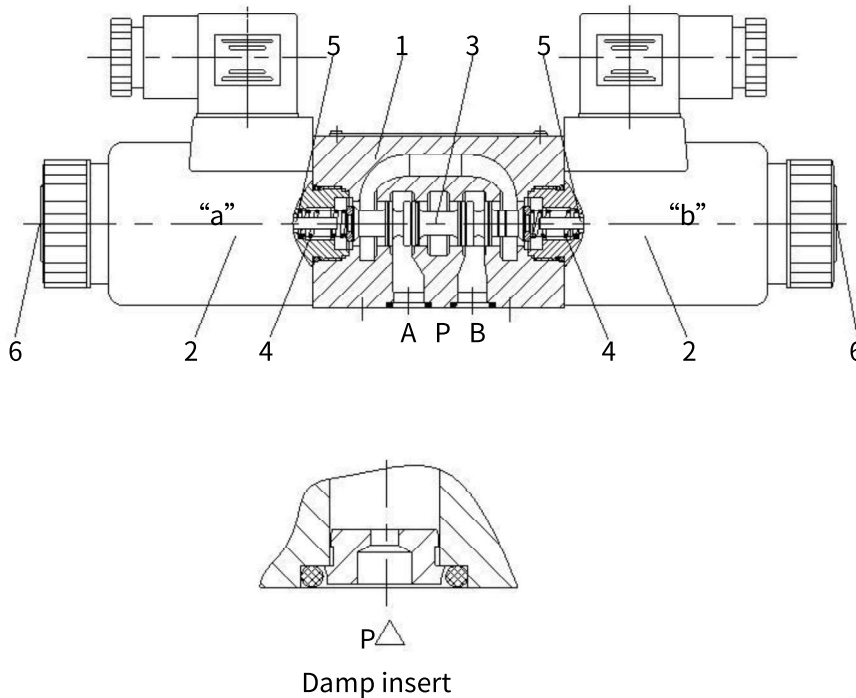

Specification

	WE	6	- 6XJ /				/			*
3 ways = 3 (For spool A and B) 4 ways = 4										Further details in clear text
Solenoid directional valve										No code=Without locating hole /60= With locating hole /62=With locating pin hole ISO 8752-3×8-St
Nominal size 6 =6										No code = NBR seals V = FKM seals
Symbols e.g. C, E etc.										No code = Without throttle insert B08 = Throttle Φ0.8 mm B10 = Throttle Φ1.0 mm B12 = Throttle Φ1.2 mm B15 = Throttle Φ1.5mm B20 = Throttle Φ2.0 mm B25 = Throttle Φ2.5 mm B30 = Throttle Φ3.0 mm
Series 60J to 69J =6XJ (60J to 69J: unchanged installation and connection dimensions)										Z4 = square plugs (not applicable for the integer) Z5L = square plugs with lamps K4 = DIN4365 sockets without plugs DL = Connecting box
With spring return = No code Without spring return =O Without spring return, and with detent =OF										
Standard solenoid =E Large-scope solenoid (Only for 12V and 24V) =N										
24V DC =G24 220V AC 50/60 Hz =W220 Plug rectification 220V =W220R 110V AC 50/60 Hz =W110										
With concealed hand emergency = N9										

Symbols

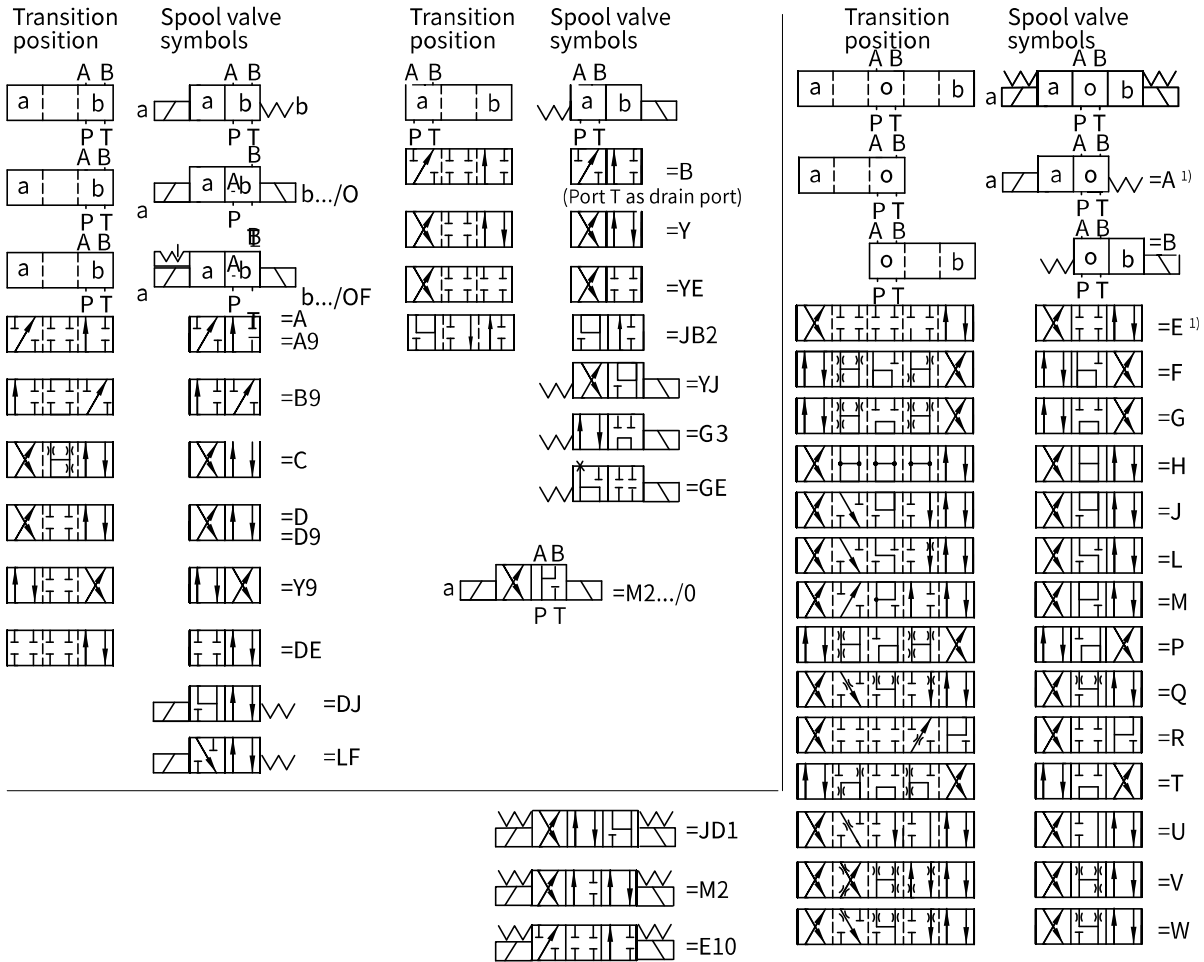

Characteristic curves

(Measured at $t=40^{\circ}\text{C} \pm 5^{\circ}\text{C}$, using HLP46)

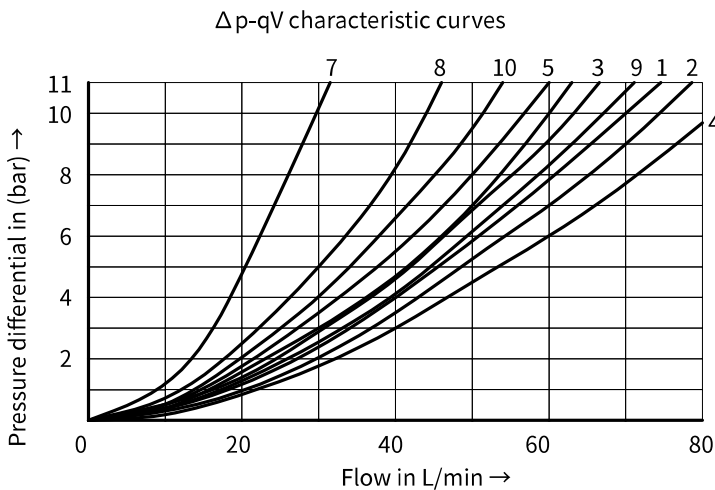

- 7 Symbol "R" in switched positions B → A
- 8 Symbol "G" and "T" in neutral position P → T
- 9 Symbol "H" in neutral position P → T

Spool symbol	Flow direction			
	P to A	P to B	A to T	B to T
A, B	3	3	-	-
C	1	1	3	1
D, Y	5	5	3	3
E	3	3	1	1
F	1	3	1	1
T	10	10	9	9
H	2	4	2	2
J, Q	1	1	2	1
L	3	3	4	9
M	2	4	3	3
P	3	1	1	1
R	5	5	4	-
V	1	2	1	1
W	1	1	2	2
U	3	3	9	4
G	6	6	9	9

Technical data

Fixing position			Optional
Environment temperature range		°C	-30 to +50 (NBR seal)
			-20 to +50 (FKM seal)
Weight	Single solenoid	kg	1.5
	Double solenoids	kg	2.0
Max. operating pressure	Port A,B,P	bar	315
	Port T	bar	210 (DC),160 (AC), when the operating pressure exceed the permission value, port T must be used as drain port for spool symbol A and B
Max. flow-rate		L/min	80 (DC), 60 (AC)
Flow cross section (switching neutral position)		mm ²	for symbol Q 6% of nominal cross section
		mm ²	for symbol W 3% of nominal cross section
Fluid		Mineral oil suitable for NBR and FKM seal	
		Phosphate ester for FKM seal	
Fluid temperature range		°C	-30 to +80 (NBR seal)
			-20 to +80 (FKM seal)
Viscosity range		mm ² /s	2.8 to 500
Degree of contamination			Maximum permissible degree of fluid contamination: Class 9. NAS 1638 or 20/18/15, ISO4406

Electric data

Type of voltage			DC	AC 50Hz
Usable voltage		V	12,24,28 ¹⁾ ,48,96,110,205,220	110, 127, 220
Permissible voltage (deviation)		%	Standard solenoid:+10~-15; Large-scope solenoid:+20~-30	
Power consumption		W	Standard solenoid:30; Large-scope solenoid:32	
Holding power		VA	-	50
Making capacity		VA	-	220
Duty			Continuous working	
Switching time to ISO 6403		ON	ms	25 to 45
		OFF	ms	10 to 25
Switched frequency		times/h	to 15000	to 7200
Type of protection to DIN 40050			IP65(Z4, Z5L plug), IP67 (K7 Deutsch)	
Max. coils temperature		°C	+150	+180

Performance limits

The specified switching performance limits are valid with two directions of flow.

Due to the flow forces acting within the valve, the permissible switching performance limit can be significantly lower with only one direction of flow! The switching performance limit was determined with the solenoid at operating temperature, at 15 % under-voltage and without tank pre-loading.

Solenoid DC		Solenoid AC-50Hz		Solenoid AC-60Hz	
Curve	Spool symbol	Curve	Spool symbol	Curve	Spool symbol
1	A, B ₁)	11	A, B ₁)	19	A, B ₁)
2	V	12	V	20	V
3	A, B	13	A, B	21	A, B
4	F, P	14	F, P	22	F, P
5	J	15	G, T	23	G, T
6	G, H, T	16	H	24	J, L, U
7	A/O, A/OF, L, U	17	A/O, A/OF, C/O,	25	A/O, A/OF, Q, W
8	C, D, Y		C/OF, D/O, D/OF	26	C, D, Y
9	M		E, J, L, M	27	H
10	E, R ₂), C/O, C/OF	18	Q, R ₂), U, W	28	C/O, C/OF, D/O
	D/O, D/OF, Q, W		C, D, Y		D/OF, M, R, E, R ₂)

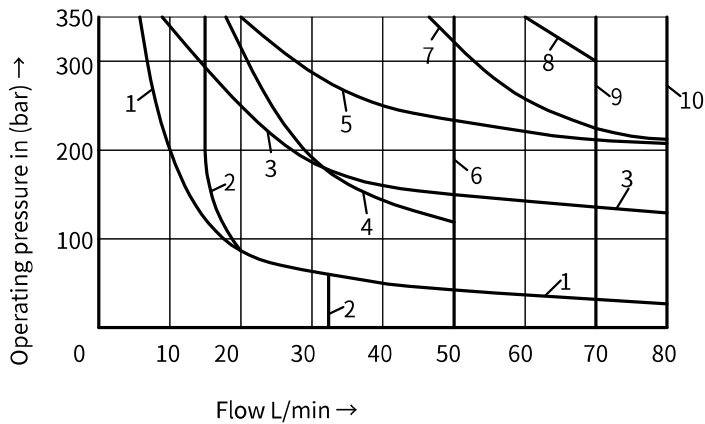

Solenoid DC	
Curve	Solenoid voltage(V)
1 to 10	12, 24, 48, 96, 205

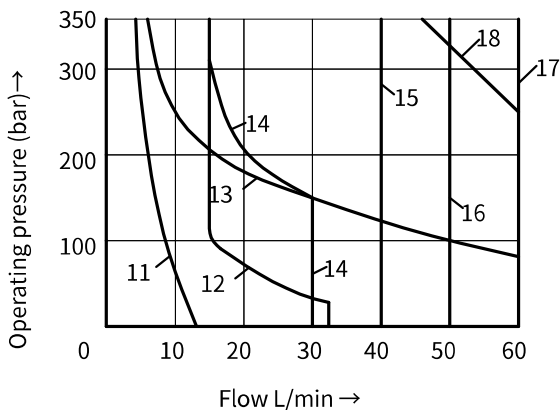

Solenoid AC		
Curve	Solenoid voltage	
11 to 18	W110	110V, 50Hz
	W127	127V, 50Hz
	W230	230V, 50Hz

Performance limits (Measured at $t=40^{\circ}\text{C} \pm 5^{\circ}\text{C}$, using HLP46)

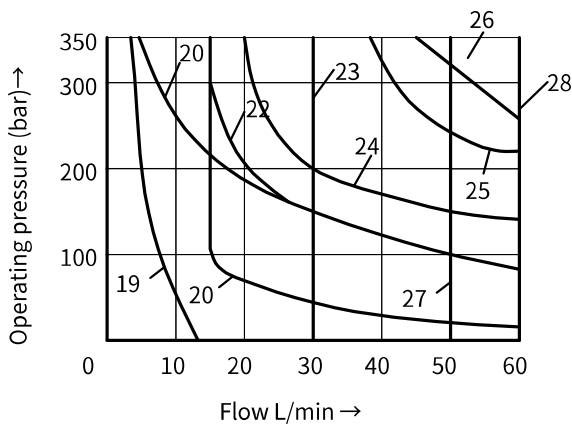

Solenoid AC		
Curve	Solenoid voltage	
19 to 28	W110	110V, 60Hz
	W230	230V, 60Hz

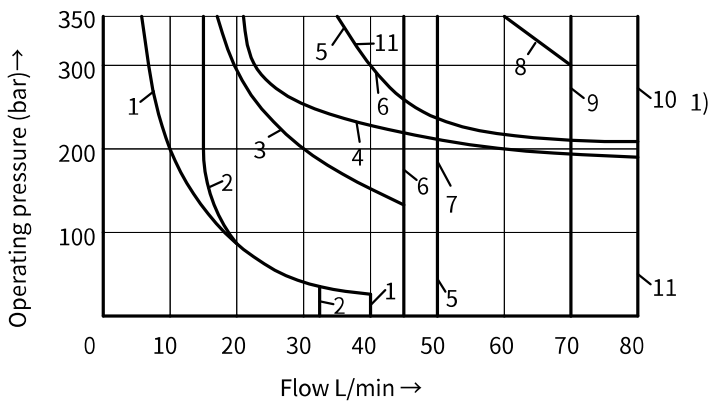

Solenoid DC	
Curve	Solenoid voltage
1 to 10 ₁	110, 180

Curve	Spool symbol	Curve	Spool symbol	Curve	Spool symbol
1	A,B	6	T	10 ₁	E, R, C/O, C/OF, D/O, D/OF, Q, W
2	V	7	H		
3	F, P	8	C,D		
4	J, L, U	9	M	11	A/O, A/OF
5	G			12	E

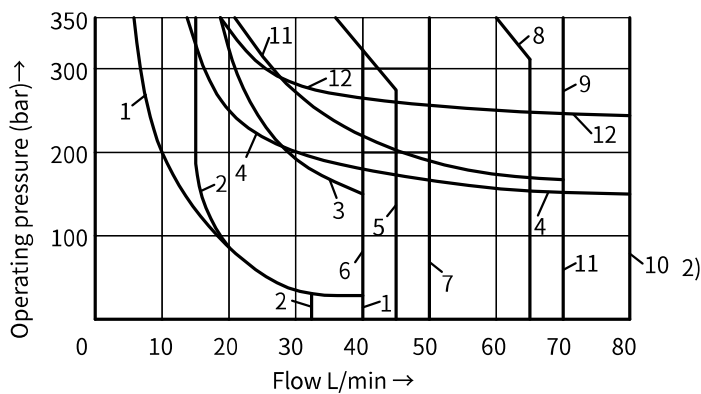

Solenoid AC	
Curve	Solenoid voltage
1 to 12, see 10 ₂	220

Unit dimensions

(Dimensions in mm)

Valve with DC or rectification AC solenoid

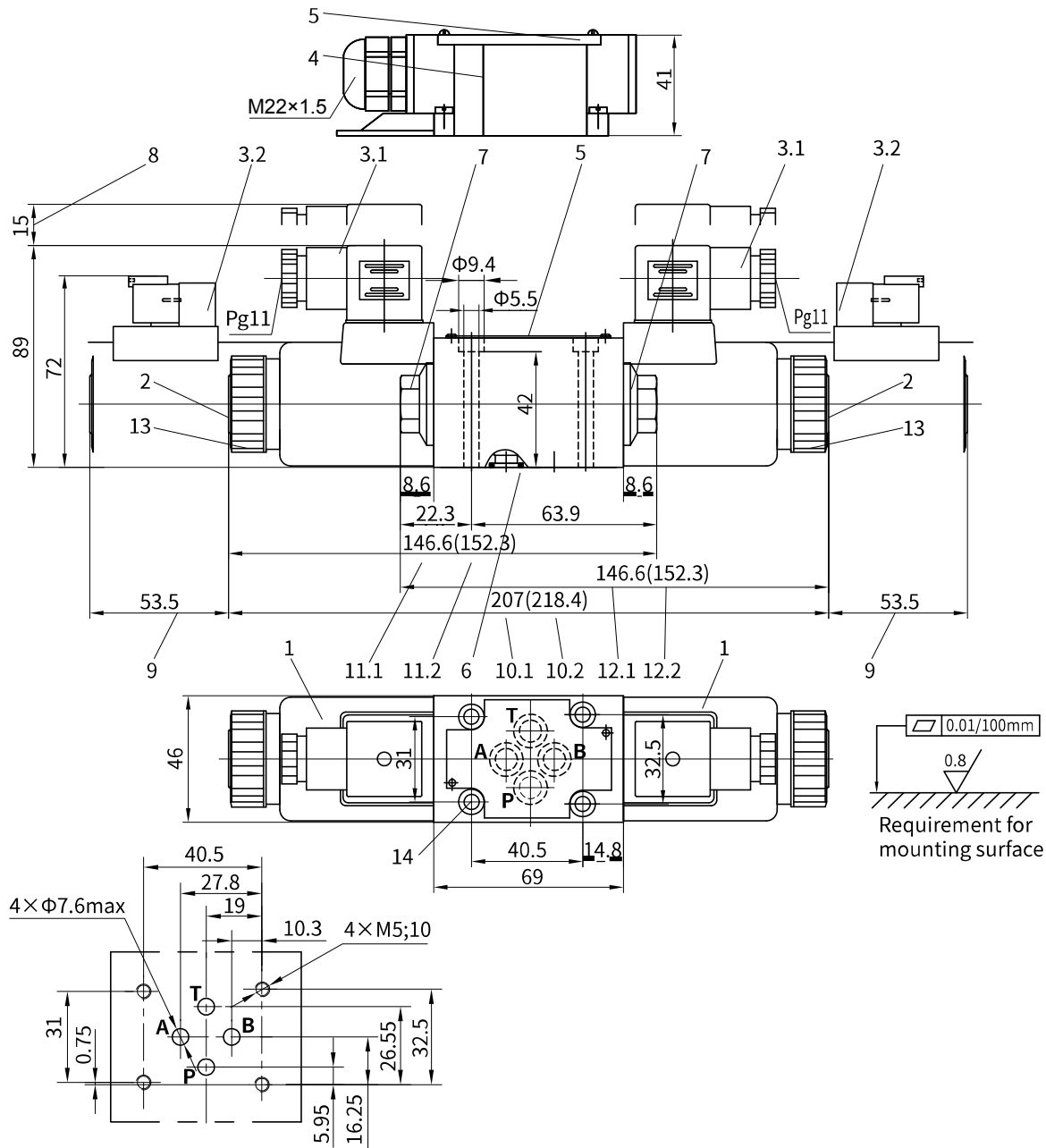

- | | |
|---|---|
| <ul style="list-style-type: none"> 1 Solenoid 2 Manual override button 3.1 Plug-in connector to DIN 43 650 3.2 Deutsch connector assembly 4 Junction box with lead and light, M22×1.5 interface 5 Nameplate 6 O-ring: 9.25×1.78 7 Plug screw for valves with one solenoid 8 Space required to remove connector 9 Space required to remove coil 10.1 Dimension of 3-position valves, standard version 10.2 Dimension of 3-position valves, large-scope Type of voltage 11.1 Dimension of 2-position valves with solenoid at 'A', standard version | <ul style="list-style-type: none"> 11.2 Dimension of 2-position valves with solenoid at 'A', large-scope Type of voltage 12.1 Dimension of 2-position valves with solenoid at 'B', standard version 12.2 Dimension of 2-position valves with solenoid at 'B', large-scope Type of voltage 13 Securing nut, tightening torque $M_A=4\text{Nm}$ 14 Valve fixing screws.
Hexagon socket head cap screw
M5×50 GB/T 70.1-10.9,
Tightening torque $M_A=8.9\text{Nm}$ |
|---|---|

Unit dimensions

(Dimensions in mm)

Valve with AC solenoid

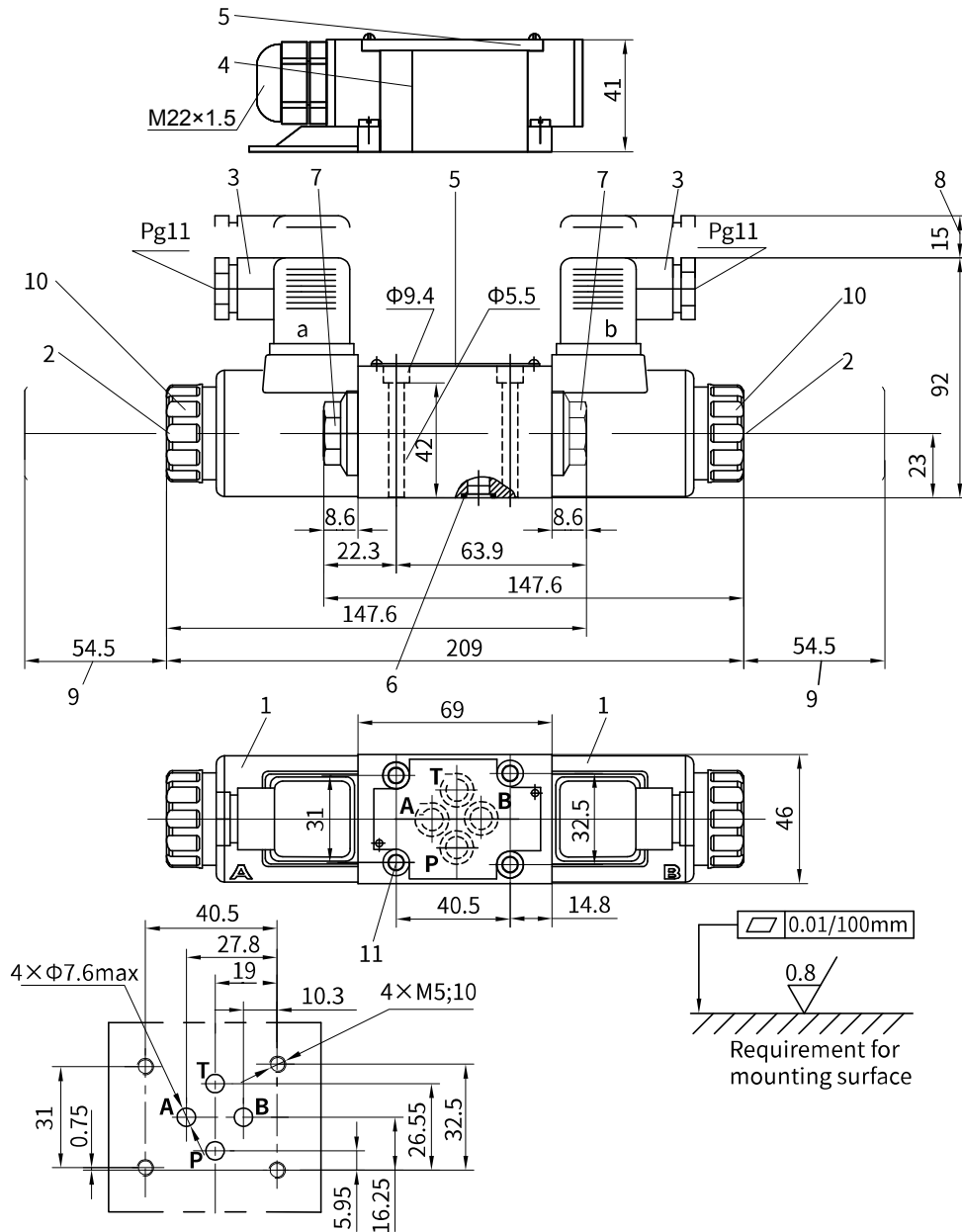

- 1 Solenoid
- 2 Manual override button
- 3 Plug-in connector to DIN 43 650 (rotatable 90°)
- 4 Junction box with lead and light, M22×1.5 interface
- 5 Nameplate
- 6 Seal rings 9.25×1.78
- 7 Plug screw for valves with one solenoid
- 8 Space required to remove connector
- 9 Space required to remove coil
- 10 Securing nut, tightening torque, $M_A = 4 \text{ Nm}$
- 11 Valve fixing screws. Hexagon socket head cap screw
M5×50 GB/T 70.1-10.9,
Tightening torque $M_A = 8.9 \text{ Nm}$