



DV(P)/D (P)...type (Check) Restrictor Valve



DV(P)/DRV(P)...10J... type

Sizes 6, 8, 10, 12, 16, 20, 25, 30
Max. Working Pressure: 350 bar
Max. Flow: 375 L/min

Contents

Function and configuration	02
Symbols	02
Specification	03
Technical data	03
Characteristic curves	04
Unit dimensions	05-08

Features

- For direct in-pipe mounting
- For control panel mounting
- Threaded connection
- Good repeatability of set values due to color scale
- Variant, optional:

Function and configuration

DV(P)/DRV(P) type valve is a flow control valve to adjust movement speed of actuators simply and exactly. The valve can also be used as shut-off valve when completely shut.

The scale of triangle shows how large the flow is (The larger the triangle is and the greater the flow is). Meanwhile, for resetting again, it can be restored to the preset position.

Type DV, DVP

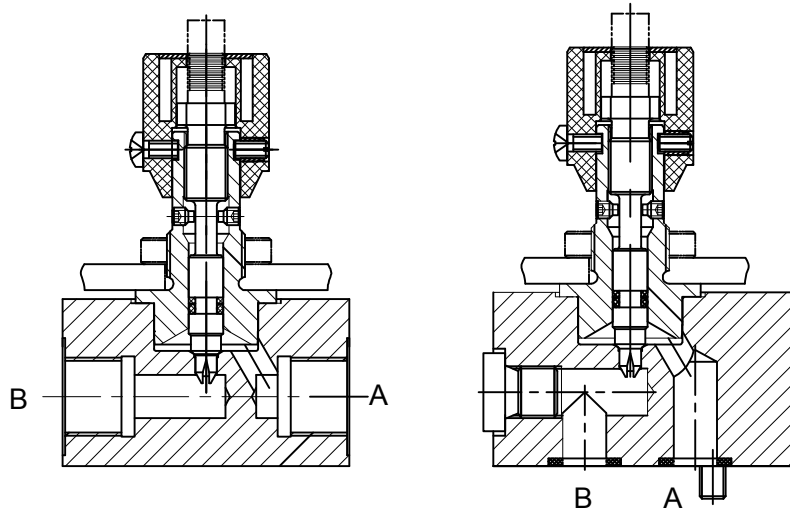

Type DRV, DRVP

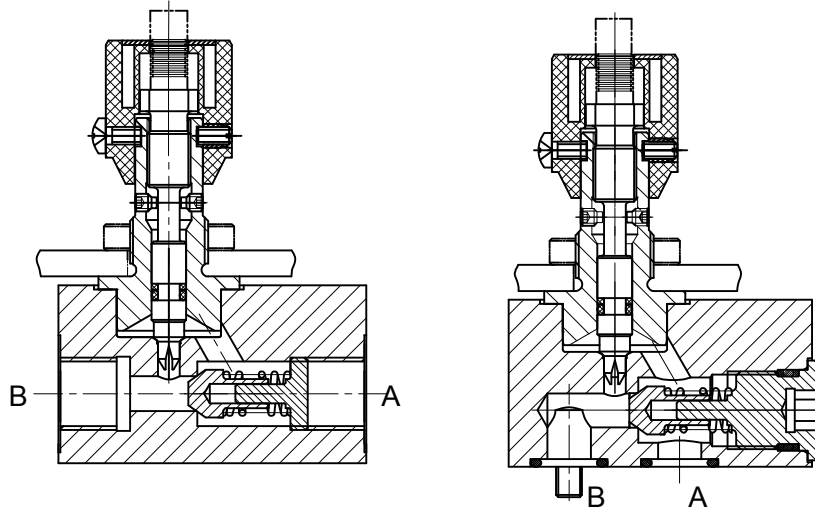

Symbols



Type DV, DVP

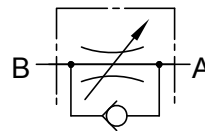

Type DRV, DRVP

Specification

			1	10J		*	
Restrictor valve	=DV						Further details in clear text
Check restrictor valve	=DRV						No code = NBR seals V = FKM seals
Threaded connection	=No code						Threaded connection
Sub-plate mounting	= P						Inch thread Metric thread
Nominal size 6	=6						No code=
Nominal size 8	=8						2 =
Nominal size 10	=10						10J=
Nominal size 12	=12						10J Series
Nominal size 16	=16						1=
Nominal size 20	=20						Steel valve body
Nominal size 25	=25						
Nominal size 30	=30						

04

Technical data

Size		6	8	10	12	16	20	25	30	
Max.Operating pressure	bar	350								
Check valve cracking pressure	bar	5								
Weight	Type DV	kg	0.12	0.53	0.7	0.9	1.5	2.5	3.3	3.8
	Type DVP		0.25	0.7	1.0	1.3	2.6	4.3	8.3	11.2
	Type DRV		0.13	0.6	0.7	0.9	1.5	3.1	4.1	5.3
	Type DRVP		0.26	0.7	1.0	1.4	2.7	4.7	8.8	12.2
Fluid		Mineral oil; phosphate ester								
Fluid temperature range	°C	-20 to +80								
Viscosity	mm ² /s	2.8~500								
Installation position		Optional								
Degree of contamination		Maximum permissible degree of fluid contamination: Class 9. NAS 1638 or 20/18/15, ISO4406								

Characteristic curves (Measured at t=40°C ±5°C, using HLP46)

Flow direction: A to B relation of differential pressure ΔP to flow Q in constant throttle position

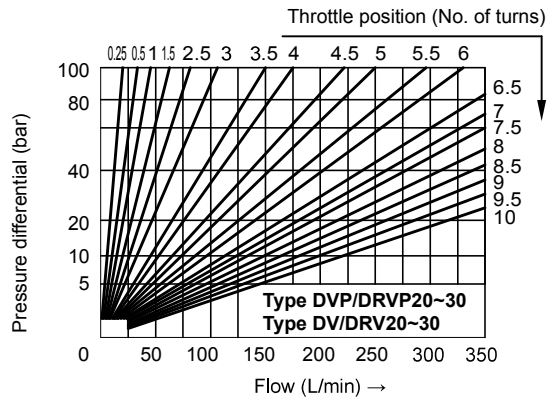
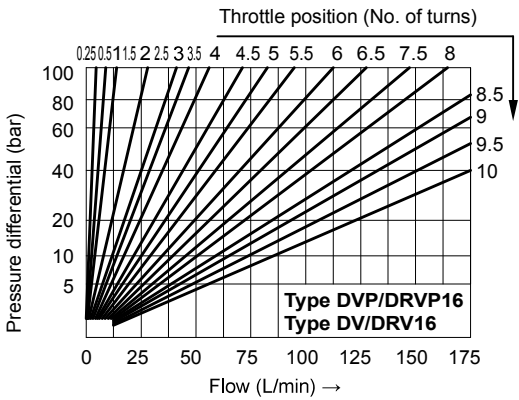
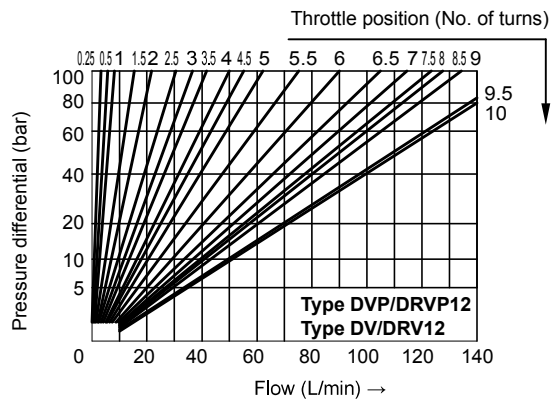
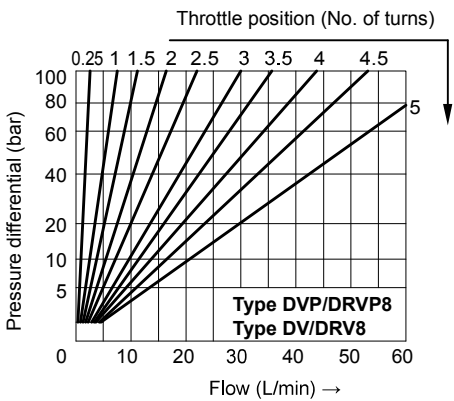
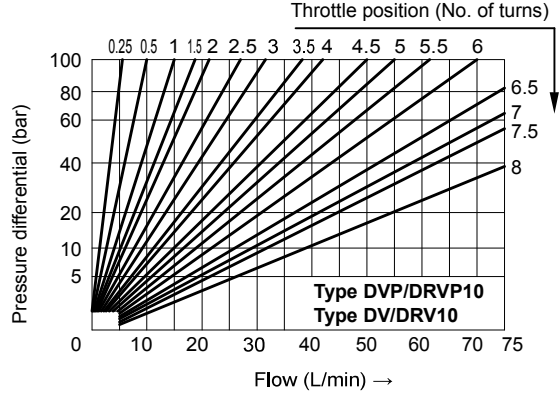
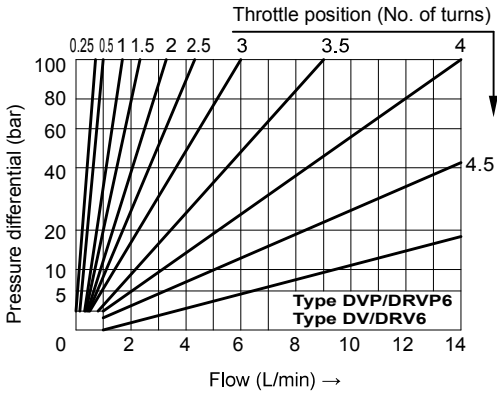

Type DRV

Flow direction: B to A P-Q curve of Free flow via open check valve

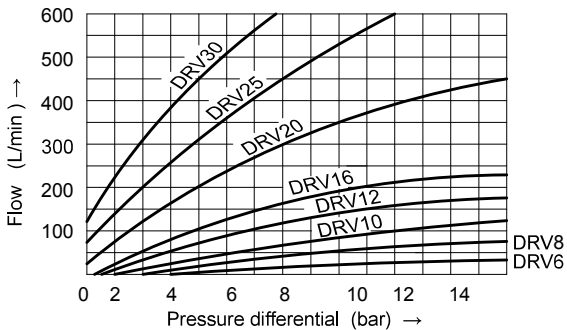

04

Unit dimensions

• Threaded-connection (Type DV)

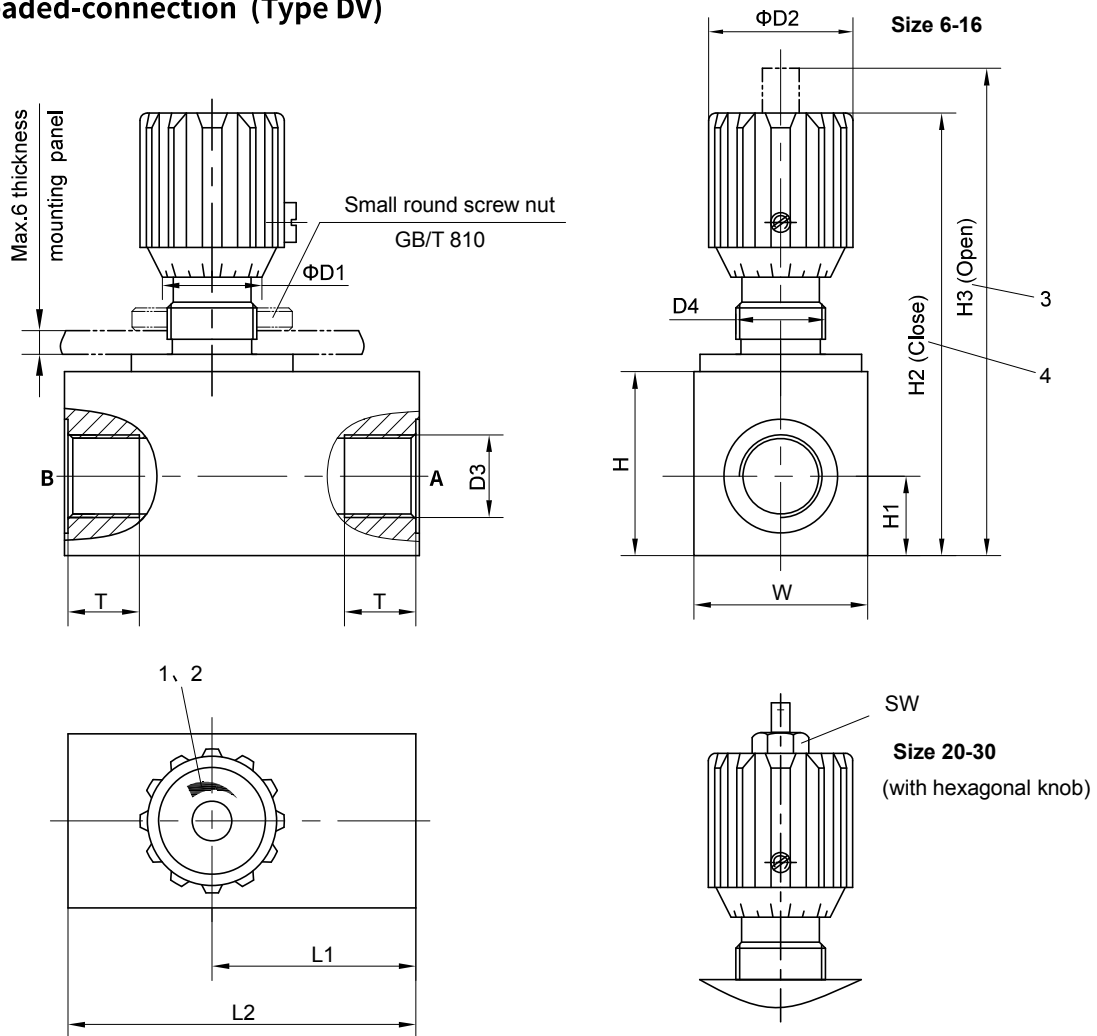

1 Flow increases with anti-clockwise rotation
2 Flow reduces with clockwise rotation

3 Throttle fully opens
4 Throttle closes

Size	W×H	ΦD1	ΦD2	D3		D4	H1	H2	H3	L1	L2	SW	T
6	20×20	15	24	G1/8	M10×1	M12×1.25	10	64	68	19.5	39		9
8	34×30.5	20	29	G1/4	M14×1.5	M18×1.5	12.5	83	90	32.5	63.5		12
10	36.5×38.5	20	29	G3/8	M18×1.5	M18×1.5	16	95	103	33	66		12
12	37×38	26	37.5	G1/2	M22×1.5	M22×1.5	17.5	101.5	109.5	44.5	80		14
16	45×52	26	37.5	G3/4	M27×2	M22×1.5	22.5	124	134.5	44.5			16
20	57×56.5	38	50	G1	M33×2	M36×1.5	26	162.5	178.5	49.5	99	19	18
25	63×66	38	50	G1 1/4	M42×2	M36×1.5	30	167	186	54.5	109	19	20
30	73×76	38	50	G1 1/2	M48×2	M36×1.5	35	177.5	196	54.5	109	19	22

Unit dimensions

• Threaded-connection (Type DRV)

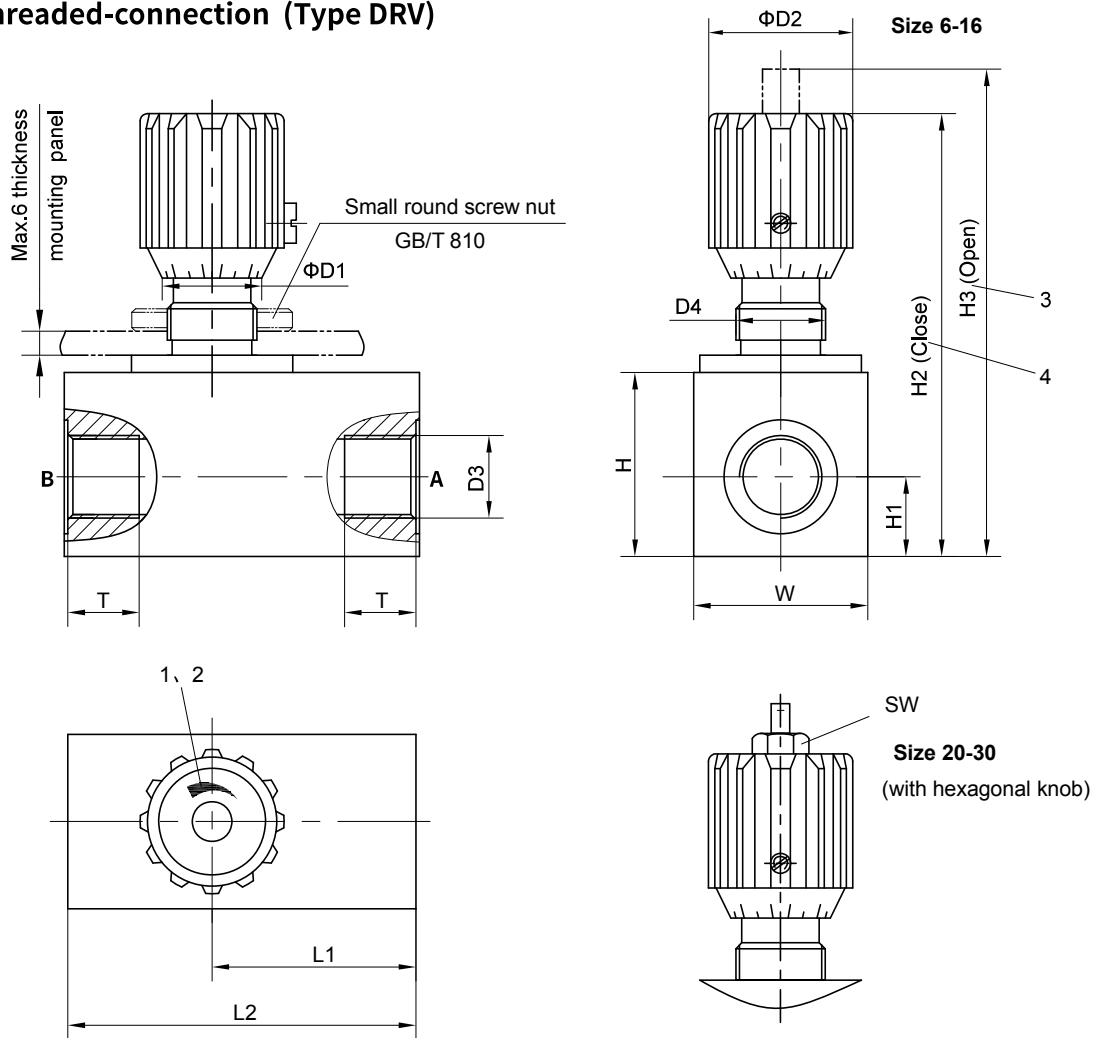

Size	W×H	ΦD1	ΦD2	D3		D4	H1	H2	H3	L1	L2	SW	T
6	20×21	15	24	G1/8	M10×1	M12×1.25	10	65	70	28	46		9
8	34×35	20	29	G1/4	M14×1.5	M18×1.5	15	87	94	38	64.5		12
10	36.5×41	20	29	G3/8	M18×1.5	M18×1.5	16	98	105	45.5	71		12
12	37×42	26	37.5	G1/2	M22×1.5	M22×1.5	17.5	105	113	48	81		14
16	45×54	26	37.5	G3/4	M27×2	M22×1.5	22.5	124	134.5	56.5	89		16
20	57×59	38	50	G1	M33×2	M36×1.5	26	162.5	178.5	80	128	19	18
25	63×70	38	50	G1 1/4	M42×2	M36×1.5	30	170	186.5	98	144	19	20
30	73×80	38	50	G1 1/2	M48×2	M36×1.5	35	180	195.5	105	145	19	22

1 Flow increases with anti-clockwise rotation
3 Throttle fully opens

2 Flow reduces with clockwise rotation
4 Throttle closes

Unit dimensions

• Sub-plate mounting (Type DVP)

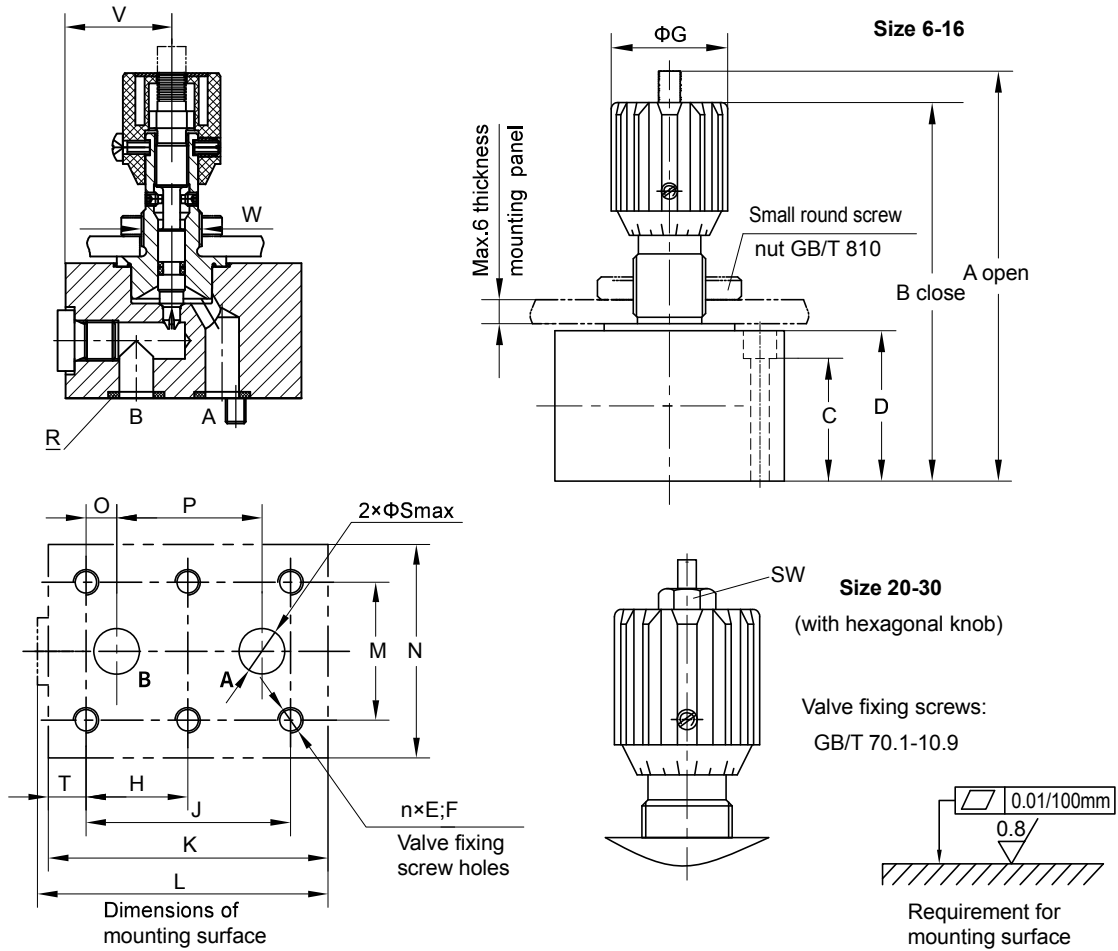

Size	A	B	C	D	n	E	F	G	H	J	K	L	M	N
6	66	61.5	10	18	4	M6	12	24	-	19	38	41	28.5	41.5
8	89.6	82.7	21	30.5	4	M6	12	29	-	35	63.5	67	33.5	46
10	104	96	29.5	40	4	M6	12	29	-	33.5	70	72.3	38	51
12	109	100.5	29	38	4	M6	12	37.5	-	38	80	82	44.5	57.5
16	133	122.3	41	52	6	M8	16	37.5	38	76	104	107	54	70
20	177	161	49	61	6	M8	16	50	47.5	95	127	129	60	76.5
25	185	170	55	68.5	6	M10	20	50	60	120	165	168	76	100
30	195	179	63	79	6	M12	24	50	71.5	143	186	186	92	115

Size	O	P	R	S	T	V	W	SW	Vale fixing screw
6	1.6	16	O-ring 7×1.5	5	9.5	18.5	M12×1.25	-	M6×20
8	4.5	25.5	O-ring 12.3×2.4	8	14.3	31	M18×1.5	-	M6×30
10	4	25.5	O-ring 12.3×2.4	10	17	31.5	M18×1.5	-	M6×40
12	4	30	O-ring 15×2.65	12	21	36.5	M22×1.5	-	M6×40
16	11.4	54	O-ring 19×3	15	14	49	M22×1.5	-	M8×55
20	19	57	O-ring 30×3	20	17	47	M36×1.5	19	M8×60
25	20.6	79.5	O-ring 32×3	25	15	77	M36×1.5	19	M10×70
30	23.8	95	O-ring 34.52×3.53	30	15	85	M36×1.5	19	M12×80

04

Unit dimensions

· Sub-plate mounting (Type DRVP)

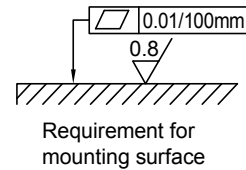
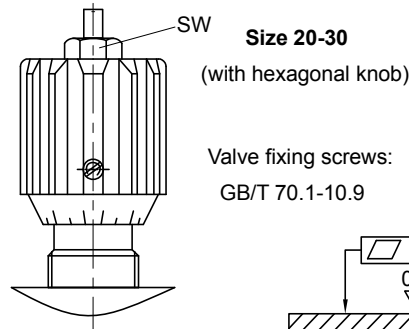
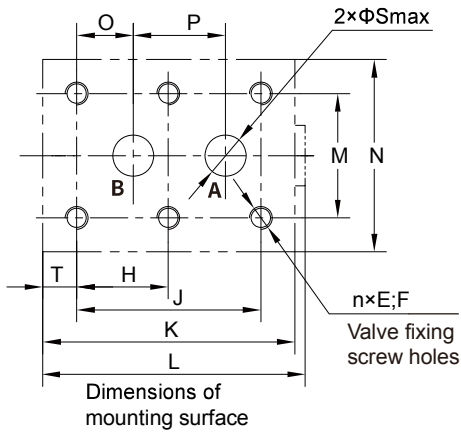
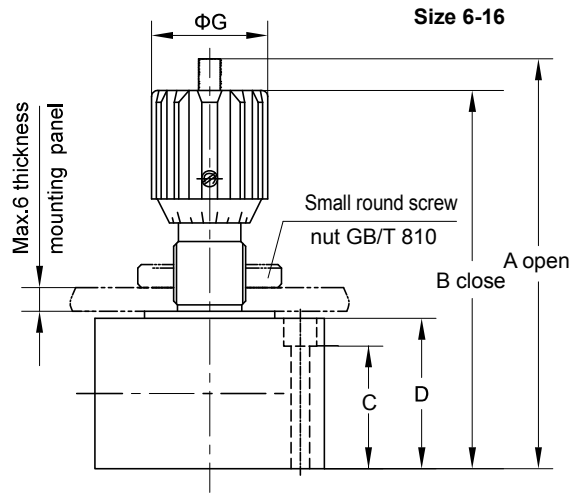
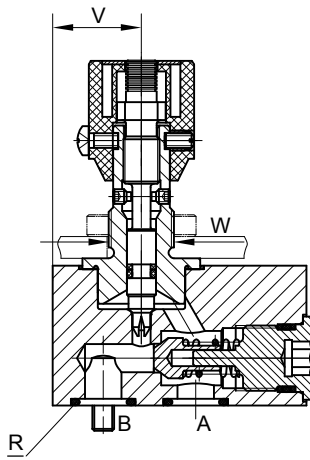

Size	A	B	C	D	n	E	F	G	H	J	K	L	M	N
6	67	62.5	9	19	4	M6	12	24	-	19	41.5	43	28.5	41.5
8	90	83	19	31	4	M6	12	29	-	35	63	67	33.5	46
10	103	95	30	38.5	4	M6	12	29	-	33.5	70	72	38	51
12	112	103.5	29	41	4	M6	12	37.5	-	38	80	84	44.5	57.5
16	132	122	41	51	6	M8	16	37.5	38	76	104	107	54	70
20	176	161	48	60	6	M8	16	50	47.5	95	127	131	60	76.5
25	186	171	55	70	6	M10	20	50	60	120	165	169	76	100
30	195	180	63	79	6	M12	24	50	71.5	143	186	190	92	115

Size	O	P	R	S	T	V	W	SW	Vale fixing screw
6	1.6	16	O-ring 7×1.5	5	6.4	10	M12×1.25	-	M6×20
8	4.5	25.5	O-ring 12.3×2.4	8	9.3	25.8	M18×1.5	-	M6×30
10	4	25.5	O-ring 13.2×2.4	10	10	24.5	M18×1.5	-	M6×40
12	4	30	O-ring 15×2.65	12	21	31.5	M22×1.5	-	M6×40
16	11.4	54	O-ring 19×3	15	14	41	M22×1.5	-	M8×55
20	19	57	O-ring 30×3	20	17	44	M36×1.5	19	M8×60
25	20.6	79.5	O-ring 32×3	25	15	62	M36×1.5	19	M10×70
30	23.8	95	O-ring 34.52×3.53	30	15	72	M36×1.5	19	M12×80